

EXERGY ANALYSIS

P.V. Aravind

**Assistant Professor, Delft University of Technology
Visiting Lecturer, TU Munich**

EXERGY

- definition
- calculation of exergy values (incl. chemical exergy)
- calculation of exergy loss
- exergy efficiencies
- visualization of exergy and exergy loss

EXERGY

PURPOSE OF EXERGY ANALYSIS

- to determine exergy losses (true thermodynamic losses) in processes and systems
- minimisation of losses / optimisation of driving forces

THIS COURSE DISCUSSES

- the calculation of exergy values:
 - exergy of heat
 - exergy of a flow of matter: thermo-mechanical exergy
chemical exergy
- calculation of exergy losses in open, steady state systems ($T_0 \cdot \Delta s_{\text{irrev}}$)
- definition of exergy efficiencies (apparatuses, plants)
- visualization of exergy losses and flows in diagrams:
 - property diagrams (T,s -, h,s -diagrams)
 - exergy flow diagrams (Grassmann-diagrams)
 - value diagrams

DEFINITION OF EXERGY

GENERAL DEFINITION:

EXERGY = the maximum theoretical work that can be obtained
from an amount of energy

A MORE COMPREHENSIVE DEFINITION:

EXERGY = the work that can be obtained from an amount of energy
(converted in a well-defined system), under ideal conditions
(applying reversible processes), using the environment only
as a reservoir of heat and matter

EXERGY ANALYSIS OF OPEN, STEADY STATE, CONSTANT VOLUME SYSTEMS

general layout of real systems (open steady state system with constant volume)

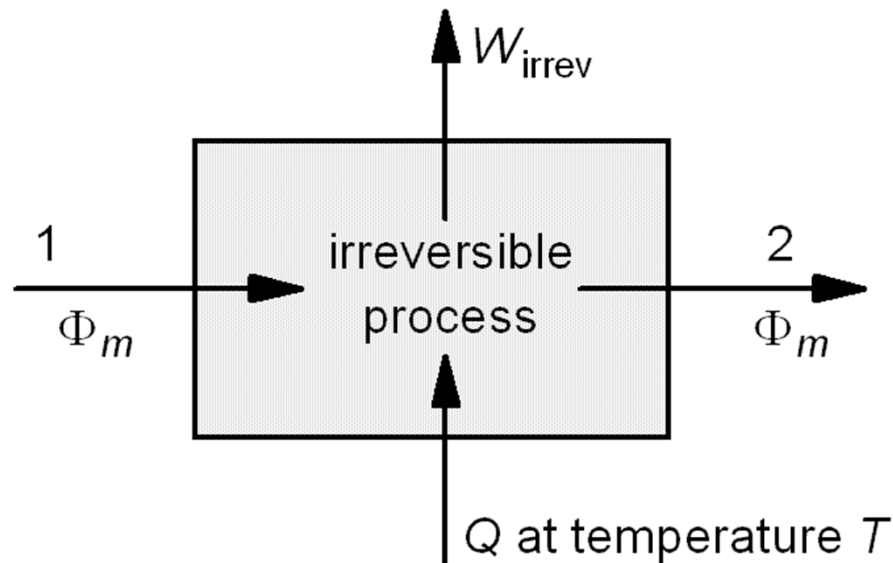

open, steady state, constant volume systems to determine:

- the exergy of heat
- the exergy of (mass) flows

(work is 100% exergy)

EXERGY OF HEAT

To calculate the exergy of heat (at temperature T):

- make use of a reversible thermal power cycle (closed cycle)
- heat is discharged only to the environment (at T_0)

maximum theoretical work from a reversible power cycle:

$$dW_{\text{rev}} = \left(1 - \frac{T_C}{T_H}\right) \cdot dQ$$

with $T_H = T$ and $T_C = T_0$:

$$dW_{\text{rev}} = \left(1 - \frac{T_0}{T}\right) \cdot dQ \quad \text{and} \quad dW_{\text{rev}} = dEX_Q$$

$$\text{thus: } dEX_Q = \left(1 - \frac{T_0}{T}\right) \cdot dQ$$

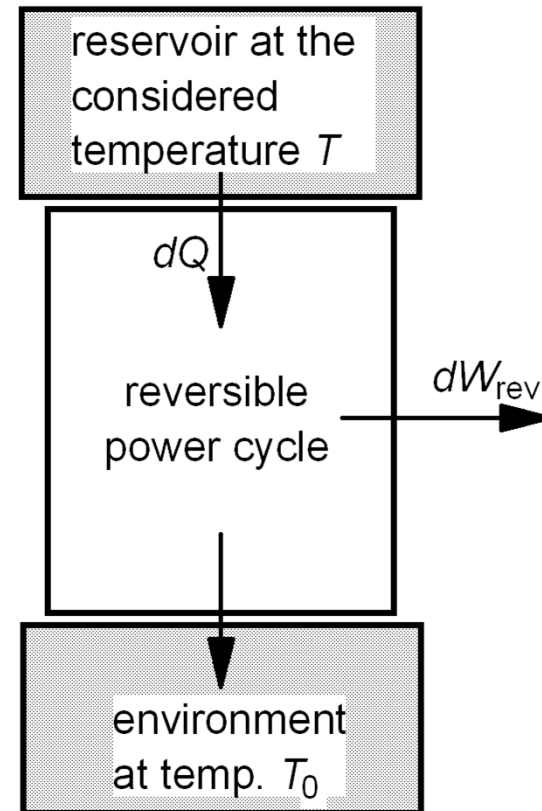

EXERGY OF HEAT

exergy of heat:

$$dEx_Q = \left(1 - \frac{T_0}{T}\right) \cdot dQ$$

in general, heat will be transferred to a system at varying temperatures:

$$Ex_Q = \int_1^2 dEx_Q = \int_1^2 \left(1 - \frac{T_0}{T}\right) \cdot dQ$$

or:
$$Ex_Q = \left(1 - \frac{T_0}{\bar{T}}\right) \cdot Q$$

\bar{T} = thermodynamic equivalent temperature of heat transfer to the cycle

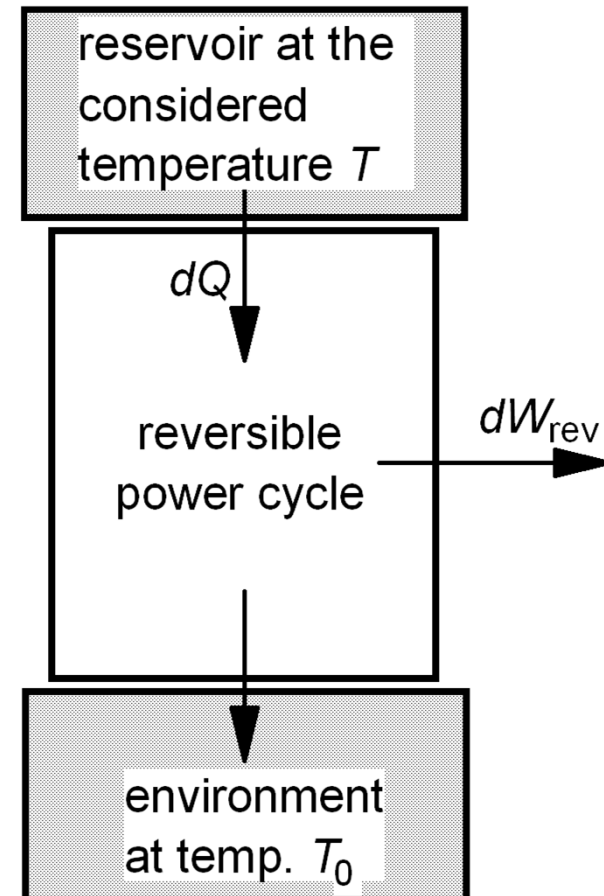

EXERGY OF A FLOW OF MATTER

Characteristics of a system used to determine the exergy of a flow of matter:

- system with only reversible processes
- steady state flow in open system with constant volume
- heat is transferred only to and from the environment at T_0
- system brings matter into equilibrium with environment

lay-out of a system that brings an amount of substance (or mass flow) into equilibrium with environment:

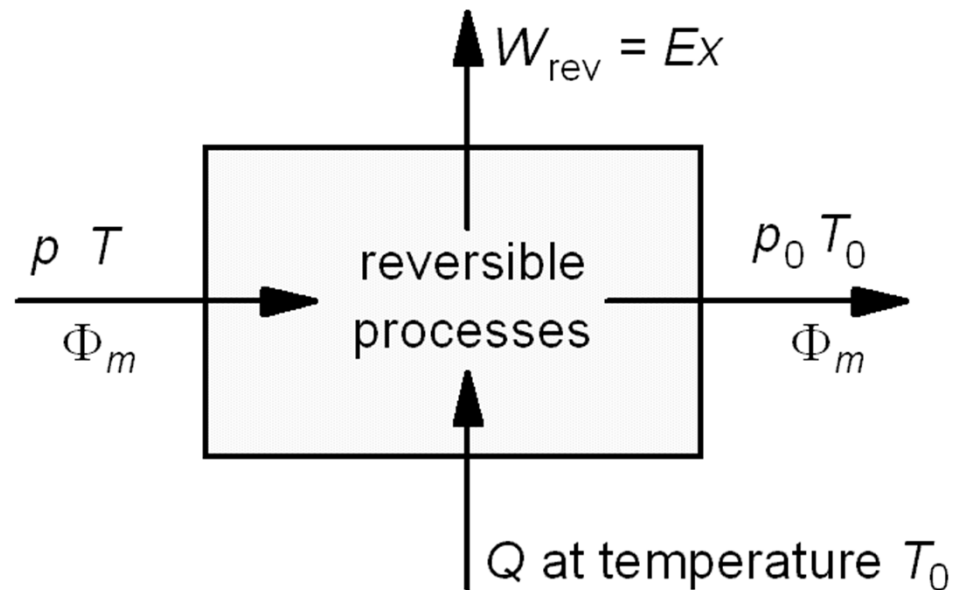

EXERGY OF A FLOW OF MATTER

equilibrium with environment
means (in this case):

- system outlet pressure equals p_0
- system outlet temperature equals T_0

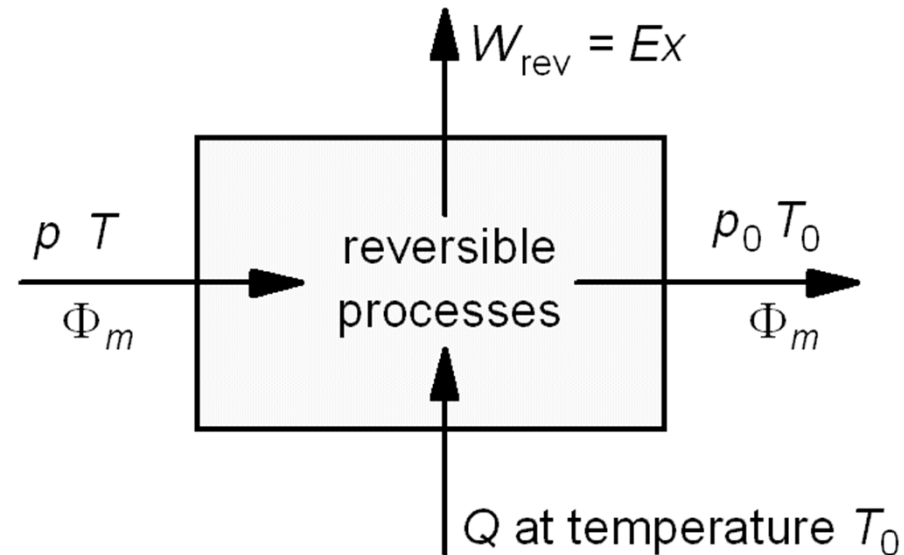

NB

- at system outlet the matter is in thermo-mechanical equilibrium with the environment
- chemical composition of matter remains unchanged
- therefore the exergy determined in this way is called:

thermo-mechanical exergy

DETERMINING THE EXERGY OF A FLOW

energy balance of an open steady state system with constant volume:

$$Q = (H_2 - H_1) + (E_{k,2} - E_{k,1}) + (E_{p,2} - E_{p,1}) + W$$

as: $E_{k,2} \approx E_{k,1}$, $E_{p,2} \approx E_{p,1}$

$$H_2 = H_0 \text{ , } H_1 = H$$

than: $Q = (H_0 - H) + W$ (1)

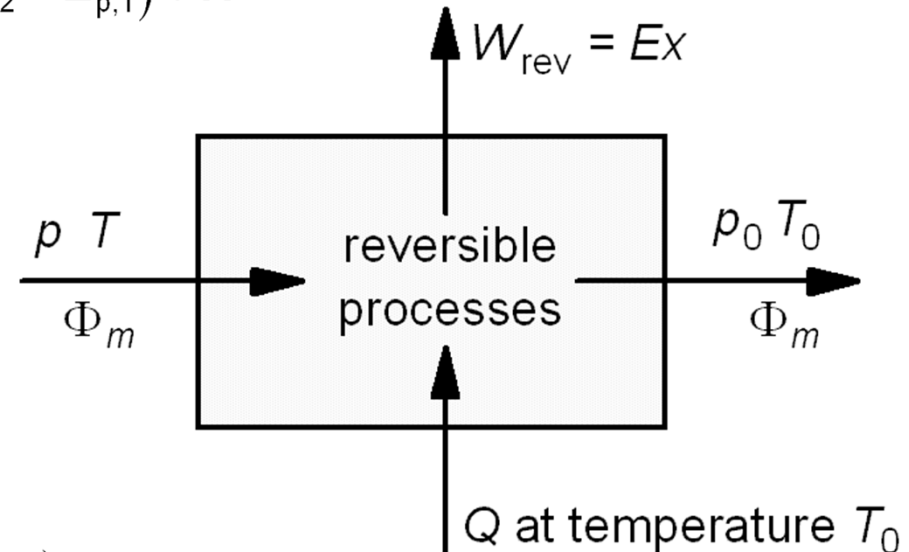

reversible processes: $Q = \int T \cdot dS$

heat is supplied at T_0 : $Q = T_0 \cdot (S_0 - S)$ (2)

combining (1) and (2):

$$W_{\text{rev}} = EX_{\text{matter}} = (H - H_0) - T_0 \cdot (S - S_0)$$

and for a flow of mass: $\Phi_{W_{\text{rev}}} = \Phi_{EX_{\text{flow}}} = \Phi_m \cdot [(h - h_0) - T_0 \cdot (s - s_0)]$

EXERGY LOSS OF AN OPEN, STEADY STATE, CONSTANT VOLUME SYSTEM

exergy balance of an irreversible system
in steady state:

$$EX_{\text{loss}} = EX_{\text{in}} - EX_{\text{out}}$$

for the considered system:

$$EX_{\text{in}} = EX_1 + \int_1^2 \left(1 - \frac{T_0}{T}\right) \cdot dQ$$

$$EX_{\text{out}} = EX_2 + W_{\text{irrev}}$$

thus:
$$EX_{\text{loss}} = EX_1 - EX_2 + \int_1^2 \left(1 - \frac{T_0}{T}\right) \cdot dQ - W_{\text{irrev}}$$

with:
$$EX_1 = (H_1 - H_0) - T_0 \cdot (S_1 - S_0)$$

$$EX_2 = (H_2 - H_0) - T_0 \cdot (S_2 - S_0)$$

can be written:
$$EX_1 - EX_2 = (H_1 - H_2) - T_0 \cdot (S_1 - S_2)$$

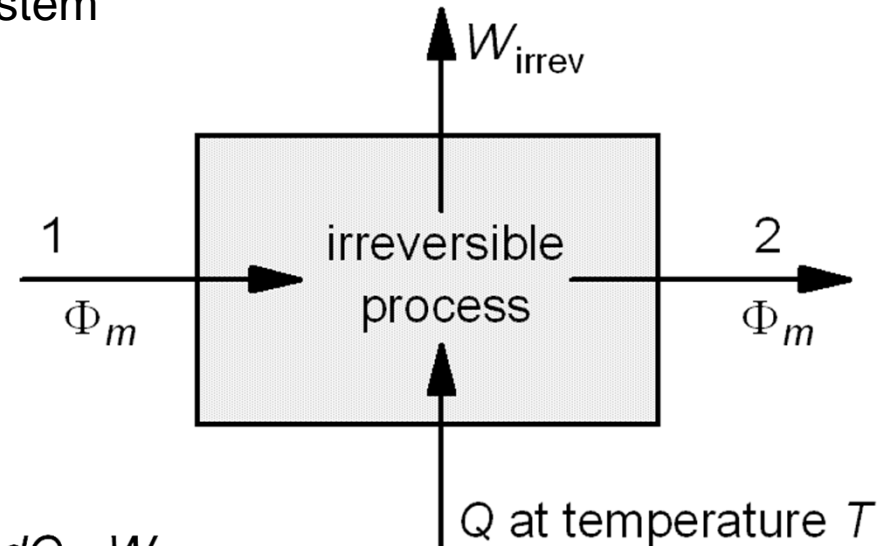

EXERGY LOSS OF AN OPEN, STEADY STATE, CONSTANT VOLUME SYSTEM

combining the results from the previous slide gives:

$$EX_{\text{loss}} = (H_1 - H_2) - T_0 \cdot (S_1 - S_2) + Q - T_0 \cdot \int_1^2 \left(\frac{dQ}{T} \right) - W_{\text{irrev}}$$

from the first law it is known that (energy balance of open steady state system):

$$Q = (H_2 - H_1) + W_{\text{irrev}} \quad \Rightarrow \quad Q + (H_1 - H_2) - W_{\text{irrev}} = 0$$

than the exergy balance becomes:

$$EX_{\text{loss}} = T_0 \cdot \left((S_2 - S_1) - \int_1^2 \left(\frac{dQ}{T} \right) \right)$$

the entropy balance is:

$$(S_2 - S_1) = \int_1^2 \left(\frac{dQ}{T} \right) + \Delta S_{\text{irrev}} \quad \Rightarrow \quad \Delta S_{\text{irrev}} = (S_2 - S_1) - \int_1^2 \left(\frac{dQ}{T} \right)$$

combining these two equations gives:

$$EX_{\text{loss}} = T_0 \cdot \Delta S_{\text{irrev}}$$

EXERGY EFFICIENCY OF HEAT EXCHANGE

possible definition of heat exchanger efficiency
(*universal efficiency*)

$$\eta_{EX, u} = \frac{\sum EX_{out}}{\sum EX_{in}} = \frac{EX_2 + EX_4}{EX_1 + EX_3}$$

as $\sum EX_{out} = \sum EX_{in} - \sum EX_{loss}$

$$EX_2 + EX_4 = EX_1 + EX_3 - EX_{loss}$$

thus $\eta_{EX, u} = \frac{EX_1 + EX_3 - EX_{loss}}{EX_1 + EX_3}$

correct definition of heat exchanger efficiency
(*functional efficiency*)

$$\eta_{EX, f} = \frac{\sum EX_{product}}{\sum EX_{source}} = \frac{EX_2 - EX_1}{EX_3 - EX_4} \Rightarrow \eta_{EX, f} = \frac{EX_3 - EX_4 - EX_{loss}}{EX_3 - EX_4}$$

note that: $EX_1 + EX_3 > EX_3 - EX_4$ and therefore: $\eta_{EX, u} > \eta_{EX, f}$

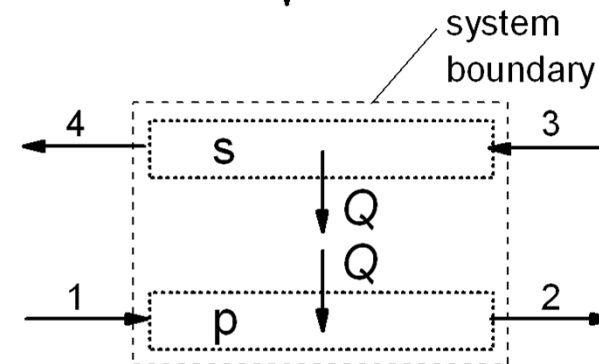
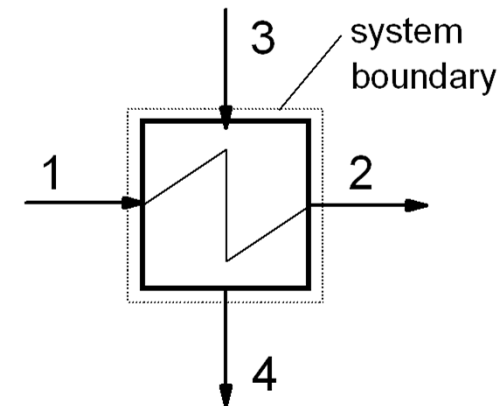

EXERGY EFFICIENCY HEAT EXCHANGE

universal exergy efficiency (should be avoided):

$$\eta_{ex, u} = \frac{EX_2 + EX_4}{EX_1 + EX_3} = \frac{(EX_1 + EX_3) - EX_{loss}}{(EX_1 + EX_3)}$$

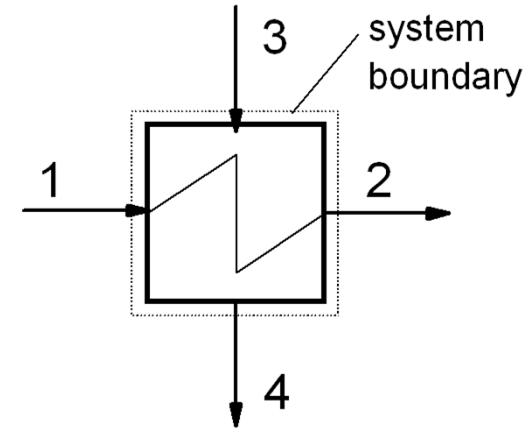

functional (correct) exergy efficiency:

$$\eta_{ex, f} = \frac{EX_2 - EX_1}{EX_3 - EX_4} = \frac{\Delta EX_p}{\Delta EX_s}$$

$$\eta_{ex, f} = \frac{\Delta EX_s - EX_{loss}}{\Delta EX_s}$$

$$\eta_{ex, f} \leq \eta_{ex, u}$$

exergy flows in heat exchanger

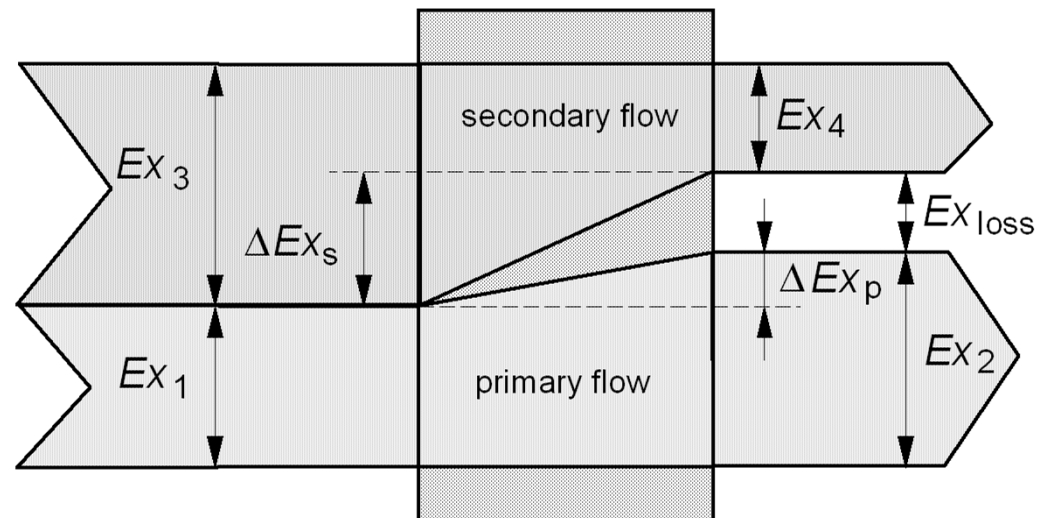

EXERGY EFFICIENCIES

CONCLUSION:

only the functional exergy-efficiency is a true thermodynamic efficiency

exergy efficiency:
(= functional efficiency)

$$\eta_{ex} = \frac{\sum EX_{\text{product}}}{\sum EX_{\text{source}}} = \frac{\sum EX_{\text{source}} - EX_{\text{loss}}}{\sum EX_{\text{source}}}$$

$\sum EX_{\text{product}}$ and $\sum EX_{\text{source}}$ have to be specified for each type of system

a universal efficiency can be used if a definition of the functional efficiency is not possible (i.e. if no product can be defined)

(universal efficiency):

$$\eta_{ex, u} = \frac{\sum EX_{\text{out}}}{\sum EX_{\text{in}}} = \frac{\sum EX_{\text{in}} - EX_{\text{loss}}}{\sum EX_{\text{in}}}$$

$\sum EX_{\text{in}}$ = exergy of energy flows entering the system

$\sum EX_{\text{out}}$ = exergy of energy flows leaving the system

note that: $EX_{\text{source}} \leq EX_{\text{in}} \quad \Rightarrow \quad \eta_{ex, f} \leq \eta_{ex, u}$

EXERGY EFFICIENCIES OF EXPANSION (TURBINE) AND COMPRESSION (COMPRESSOR)

exergy efficiency of steam turbines:

$$\eta_{ex} = \frac{EX_{product}}{EX_{source}} = \frac{W}{EX_{in} - \sum EX_{out, steam}}$$

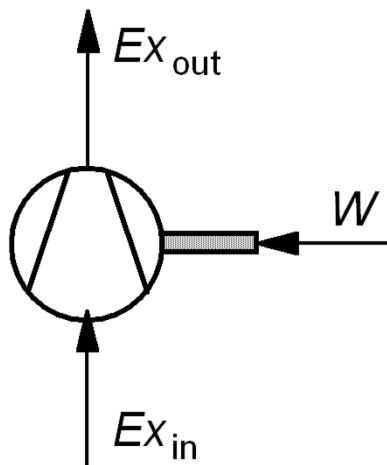
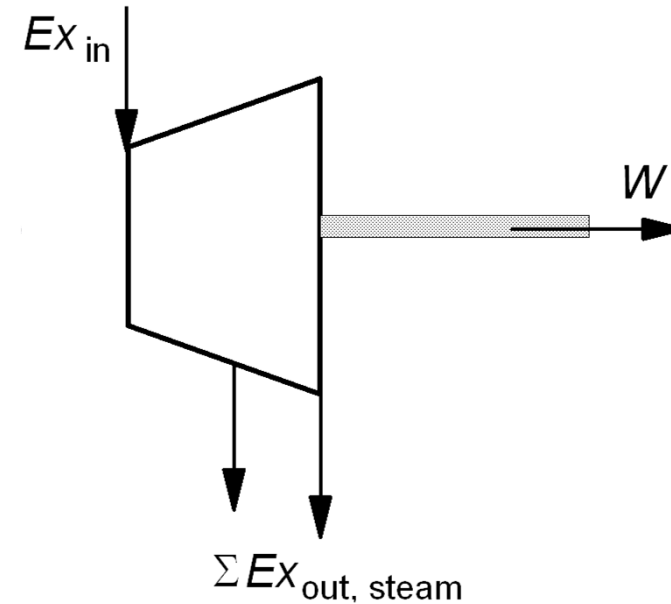

exergy efficiency of compressors:

$$\eta_{ex} = \frac{EX_{product}}{EX_{source}} = \frac{EX_{out} - EX_{in}}{W}$$

EXERGY EFFICIENCY COMBUSTION (adiabatic combustion)

exergy efficiency of adiabatic combustor:

$$\eta_{ex} = \frac{EX_{product}}{EX_{source}} = \frac{EX_{flue\ gas}^{tm} - EX_{fuel}^{tm} - EX_{air}^{tm}}{EX_{fuel}^{ch} + EX_{air}^{ch} - EX_{flue\ gas}^{ch}}$$

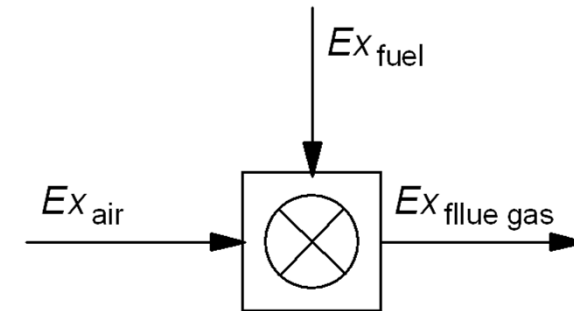

with: $EX_{flue\ gas} = EX_{flue\ gas}^{tm} + EX_{flue\ gas}^{ch}$ etc.

EX^{tm} = thermo-mechanical exergy

EX^{ch} = chemical exergy

if fuel and oxidant are supplied at environmental temperature

$$EX_{air}^{tm} = 0 \quad \text{and} \quad EX_{fuel}^{tm} = 0$$

and the equation simplifies into:

$$\eta_{ex} = \frac{EX_{flue\ gas}^{tm}}{EX_{fuel}^{ch} + EX_{air}^{ch} - EX_{flue\ gas}^{ch}}$$

EXERGY EFFICIENCIES

CONCLUSION:

the functional efficiency is the only true thermodynamic efficiency

therefore:

exergy efficiency:

(= functional efficiency)

$$\eta_{ex} = \frac{\sum EX_{\text{product}}}{\sum EX_{\text{source}}} = \frac{\sum EX_{\text{source}} - EX_{\text{loss}}}{\sum EX_{\text{source}}}$$

definition of exergy efficiencies of specific processes see BB wb4302:

course documents/additional information/appendix exergy efficiencies

however in cases where no product can be defined the universal efficiency enables a thermodynamic comparison of alternative systems

universal efficiency:

$$\eta_{ex, u} = \frac{\sum EX_{\text{out}}}{\sum EX_{\text{in}}} = \frac{\sum EX_{\text{in}} - EX_{\text{loss}}}{\sum EX_{\text{in}}}$$

warning: be very careful with using efficiencies for the assessment of the thermodynamic quality of processes or systems!!!